

72 Little Francis Street Collingwood VIC

 2
  1
  1

When Value Meets Yours Demands...

Architecturally innovative and designed for sophisticated living, is this modern residence with its own lock up garage. It's just a stone's throw to Johnston Street attractions and walking distance to Smith & Gertrude Street's loved lifestyle amenities, making it perfect for lovers of urban living.

Offering an unexpected sense of privacy over 3 exciting levels, its very suave and sexy light filled interior features totally independent zones that offers a generous open plan living that connects to two outdoor retreats, edgy & cool kitchen well-equipped with dishwasher, 2 bedrooms that share a double shower bathroom on the top level and a separate home office on the lower level perfectly zones work life away from home.

Other attributes include: Auto garage with direct internal entry, separate laundry, loads of natural light and lots more.

Type : House
Date Available : Saturday, 3rd September 2022
View : <https://www.thebisiagent.com.au/lease/vic/inner-city/collingwood/residential/house/7172975>

Northcote Rental Department **Mark Bisignano**
 03 9489 1030 03 9489 1030

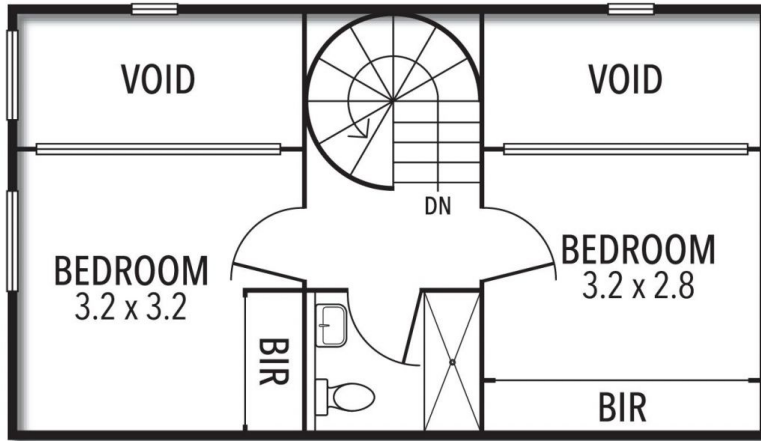

SECOND FLOOR

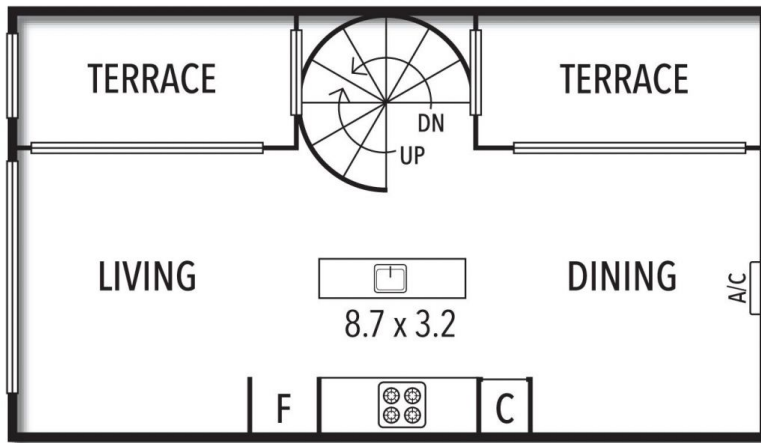

FIRST FLOOR

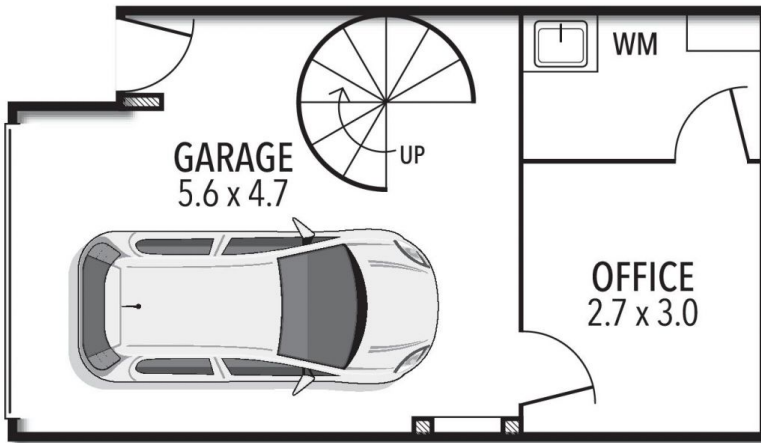

GROUND FLOOR



THE ABOVE PLAN IS AN ARTIST'S IMPRESSION ONLY, IT INCLUDES ELEMENTS THAT ARE FOR DISPLAY PURPOSES ONLY AND MAY NOT BE TO SCALE. LANDSCAPING SHOWN IS INDICATIVE ONLY. DIMENSIONS ARE APPROXIMATE.